

Curvature Loss Optical Fiber Analysis of Head Passive Sensor on the Mandrell Fiber

Harry Ramza^a, and Yohannes Dewanto^b

^aDepartment of Electrical Engineering, Faculty of Engineering, Universitas Muhammadiyah Prof. Dr. HAMKA
Jalan Tanah Merdeka No.6B, Kp Rambutan, Jakarta 13830, Indonesia
Telp : (+62-21)-8400941, Fax : (+62-21)-87782739, E-mail : ramza.harry@gmail.com

^bDepartment of Electrical Engineering, Faculty of Engineering, Universitas Surya Darma
Jl. Protokol Halim Perdanakusuma Komplek Bandara Halim Perdanakusuma Jakarta Timur 13610, Indonesia
Telp : (+62-21)-8009249 Facs: (+62-21)-8093475, E-mail : dewantoandreas@yahoo.com

Abstract

In this research, the curvature loss of optical fiber had been measured to be used as Head Passive sensors. This measurement produces the data in the form of output power from varying value of curvature radius. The length of optical cable is 2.173 m, the laser power is 0.53 mW and the power output of focal lens is 0.26 mW. The data obtained is an optical output power with radius of curvature from 1 cm until 20 cm. This will be determined curvature coefficient of weakening or loss. A variation of curvature radius that was tested from 1 cm to 20 cm with an increment step is 1 cm.

Keywords: Curvature loss, optical fiber, mandrell, passive sensor.

1. Introduction.

The optical fiber passive sensor is most widely used on the mechanical measurements[1-3], such as; acoustic wave detection[4], pressure detection, strain and thermal detection. One of the optical sensing area is known as head sensor. Generally, the type of acoustic measurements uses a modified optical head sensor.

For this type of acoustic measurements[4], generally use as an optical sensor head that has been modified to produce information from the mechanics vibration. Acoustic vibrations will affect the index of refraction on the optical sensor head. Modification of optical fiber reels is made by using Mandrell. This method is formed to produce attenuation coefficient of the optical fiber[5].

In previous research has been conducted on interference detection in underwater acoustic wave. The mandrell fiber serves as a passive detector using a single mode optical fiber and has a lot of winding numbers. Number of windings of the Mandrell fiber will produce very large losses known as curvature loss optical fiber.

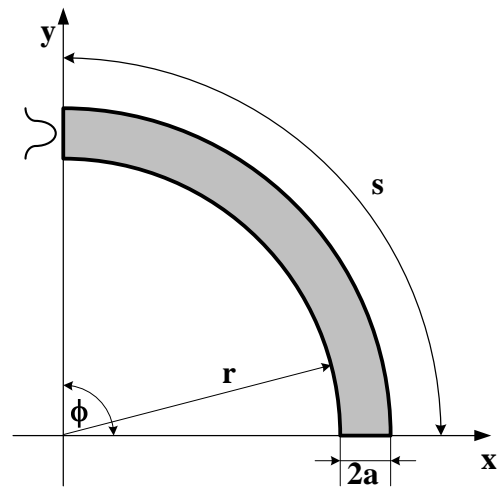

Fig 1. a quarter-curvature on the fiber optic.

In fig 1 above can be stated that r is radius of curvature, s is the circumference of a circle, ϕ is the angle of the circle. The circumference of a circle equation can be expressed in the form,

$$s = \phi r = 2 \pi r \quad (1)$$

For the number of circles or of the optical fiber for more than N -roll, then equation (1) above can be written as,

$$s = N\phi r = N2\pi r \quad (2)$$

If the optical input power source is represented (P_{in}) with fiber path length is denoted by S . Thus the power output is issued,

$$P_{out} = P_{in} e^{-\alpha s} \quad (3)$$

from equation (3) above, the value of α is expressed as attenuation coefficient of radiation. Hence, the coefficient with a radius curvature (r) will have the equation form by Dietrich Marcuse formula[6],

$$\alpha = C_1 \exp(-C_2 r) \quad (4)$$

in equation (4) above, the C_1 and C_2 are constants that depend on the size and shape of waveguide optical modes.

Equation (4) is also the key idea that the coefficient of radiation loss depends on the exponential radius curvature. Radius of curvature that allowed for radiation loss is smaller than 0.1 dB/cm which has been calculated by Goell for some form of dielectric waveguides.

From equation (4) above the curvature critical radius can be obtained[2, 6],

$$r_{critical} = \frac{1}{C_2} \quad (5)$$

Loe equation for the coefficient of fiber loss is expressed as equation[1];

$$C_1 = \frac{2\gamma^2}{k_0 n_2 (\gamma a + 2)} \cos^2\left(\frac{\kappa h}{2}\right) e^{\gamma h} \quad (6)$$

and

$$C_2 = \frac{2\gamma(n_{eff} - n_2)}{n_2} \quad (7)$$

whereby,

h is diameter of curvature. The value of field decay level on the core and cladding can be expressed as[1, 6, 7],

$$\begin{aligned} \kappa &= k_{core}^2 - \beta^2 \\ &= k_0^2 n_1^2 - n_{eff}^2 k_0^2 \end{aligned} \quad (8)$$

also,

$$\begin{aligned} \gamma &= \beta^2 - k_{clad}^2 \\ &= n_{eff}^2 k_0^2 - k_0^2 n_2^2 \end{aligned} \quad (9)$$

β as propagation constant, k_0 as wave number in free space and n_{eff} as effective refractive index between core and cladding.

To get the value of effective refractive index, the symmetric waveguides equation can be used[1, 2, 6-8];

$$\begin{aligned} \tan\left(\kappa \frac{h}{2}\right) - \frac{\gamma}{\kappa} &= 0 \\ \tan\left(\left(k_0^2 n_1^2 - n_{eff}^2 k_0^2\right) \frac{h}{2}\right) - \frac{\left(n_{eff}^2 k_0^2 - k_0^2 n_1^2\right)}{\left(k_0^2 n_1^2 - n_{eff}^2 k_0^2\right)} &= 0 \end{aligned} \quad (10)$$

Equation (10) can be calculated by using the numerical analysis.

2. Setup Experiment.

This experiment carried out by measuring the output power of single mode optical fiber[9, 10]. Refractive index of core (n_1) and cladding (n_2) are 1.468 and 1.458 respectively. In the middle of optical fiber is fabricated to be circle fiber based on the determined variation.

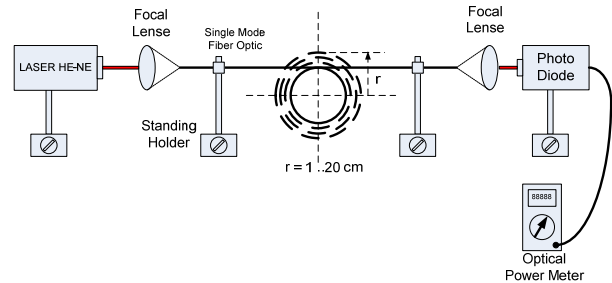

Fig 2. Experimental set-up.

As seen in Fig 2 above, the light beam of laser diode is focused using a lens[11]. The focal lens work as the coupler. Coupler works to drive the beams from the transmitter to the channel. The channel in this experiment is the optical fiber[12]. This could prevent the optical misalignment. This method is used for transmitting the laser beam from the transmitter to the optical fiber that work as the channel.

The measurement data is taken by rolling the optical fiber at the center of the channel. From there, the value of radius of the circle and the output power is measured. Optical power meter is used to get the ready of output power.

In this experiment, there is only one parameter that need to vary to observe for data analysis, that is the curvature. The number of winding of the optical fiber at the

center of the channel is fixed to 1. It was conducted in stages at each measurement data.

Table 1. Experiment results.

Radius of curvature (cm)	Output Power (uwatt)
1	3.20
2	3.40
3	4.70
4	5.20
5	5.80
6	5.86
7	6.00
8	6.15
9	6.20
10	6.40
11	6.65
12	6.85
13	7.00
14	7.90
15	8.00
16	8.00
17	8.00
18	8.00
19	8.00
20	8.00

In the above measurements using a light source He-Ne laser with wavelength (λ) = 632 nm, laser power at 0.53 mWatt. To guide the laser light into the fiber optic used the focus lens with optical output power at 0.26 mWatt. Optical fiber path length of the under test is 2.173 m.

3. MATLAB Programming.

In this experiment, simulation analysis needs to be done to get the value of effective refractive index by using a bisection method. This method is performed using MATLAB simulation. Script programs can be seen below,

```
% Bisection Method for calculation of Refractive Index
effective
% By Harry Ramza
% SPECTEC Research Group, Department of Electrical
Engineering
%The National University of Malaysia
%Bangi, Selangor D. E., MALAYSIA
%
function bisect(f,h,a,b)
tol=0.0000000001;
fa=feval(f,h,a);
fb=feval(f,h,b);
if (tol<=0)
    fprintf('Tol must be positive value\n');
    return
end
if(fa*fb>0)
    fprintf('Value a and b un-interval range\n');
else
    while 1
        if (abs(b-a)<=tol)
            break
        end
```

```
c=(a+b)/2;
fc=feval(f,h,c);
if(c==a|c==b)
    fprintf('Maximum possible precision achieved\n')
    break
end
if(fa*fc>0)
    a=c;
    fa=fc;
else
    b=c;
    fb=fc;
end
end
fprintf('Effective Refractive Index (Neff)=%18.9f\n',c);
end
%
```

To obtain the f function from the above program, we can use equation (10) to get the effective refractive index equation. This equation can be made into a separate program.

```
%
function y=f(h,x)
y=tan((h*pi/1.55)*sqrt(1.468^2-x.^2))-(sqrt(x.^2-
1.458^2))/(sqrt(1.468^2-x.^2));
%
```

Both programs will result in effective refractive index of (n_{eff}) 1.463965708. These results will be included in the curvature loss calculation of the optical fiber that will be determined later.

4. Experiment Results.

The results obtained from experiment can be compared with simulation results. The simulation results obtained are:

- Critical radius is 0.226 cm.
- Attenuation coefficient (α) 2.34 dB/Km.
- C1 and C2 constant are 4.874×10^{-8} and 4.418×10^{-3} respectively.
- The value of field decay level on the core (κ) and cladding (γ) are 0.439 and is 0.537 respectively.
- In figure 3 can be seen the difference between experiment and theory graph. For the square marked line (output power in theory) would produce exponential equation form,

$$y = 0.649 e^{0.147x} \quad (11)$$

and experiment on the lines marked with circles will generate,

$$y = 4.066 e^{0.041x} \quad (12)$$

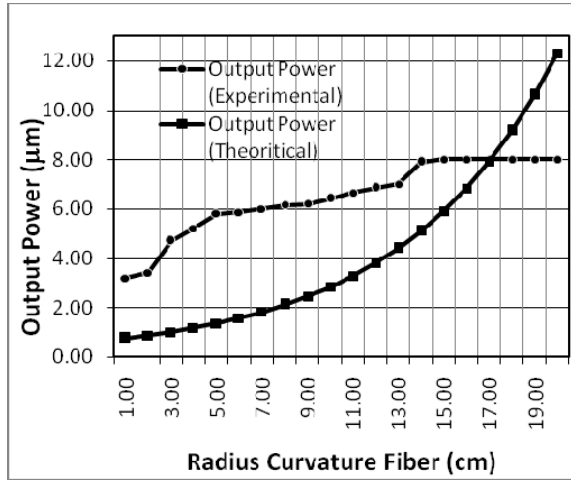

Fig 3. Power output graph due to fiber curvature.

Fig 3 above, explained the phenomena of output power saturation beginning at the curvature value at 15 cm onwards. The intersection point between the theory and practical graph occurred at the early stage of output power saturation, that is at 17 cm of radius curvature fiber.

From table 1, it can see the factor of the attenuation coefficient at any curvature of the fiber as shown in Fig 4. Equation graph of figure 4 can be written into the form of an exponential equation,

$$y = 0.133 e^{-0.13x} \tag{13}$$

In Figure 4, the variation of curvature values in meter and curvature loss (α) divided by 1000 to declare dB/km. Curvature loss value is obtained from the equation (3) so that [1, 5, 10],

$$\frac{\alpha(dB/Km)}{1000} = -\left(\frac{10}{2\pi R}\right) \log\left(\frac{P_{out}}{P_{in}}\right) \tag{14}$$

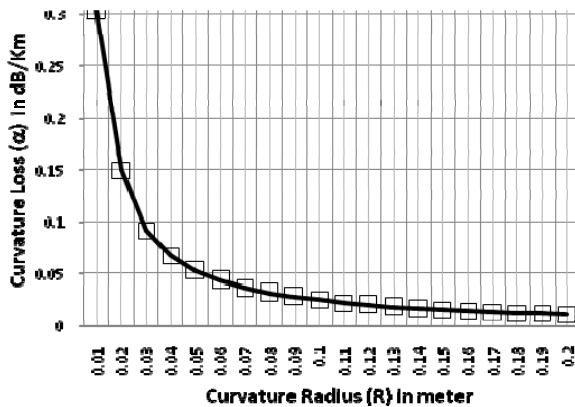

Fig 4. Curvature loss (α) graph with variety of diameter.

5. Conclusion.

Effective refractive index value optical fiber are developed using MATLAB programs. The result of effective refractive index is used to obtain field decay level values (γ and κ). The difference of multiplication constant between experiment and theory is 0.649 and 4066.

Attenuation factor that obtained from the experimental works is 0.041 compared to the theory value that is 0.147. The factor divider is divided by 1000 to get the value of curvature loss (α) in dB/Km.

References

- [1] C. L. Chen, *Elements of optoelectronics and fiber optics*: Irwin, (1996).
- [2] W. A. Gambling, H. Matsumura, and C. M. Ragdale, "Curvature and microbending losses in single-mode optical fibres," *Optical and Quantum Electronics*, vol. 11, pp. 43-59, (1979).
- [3] H. Ramza, A. Syahriar, and H. Zain, "The Effects of Stress in Fiber Optic and It's Application on Mach-Zehnder Interferometer," in *Indonesian German Conference, IMCF-ITB*, Bandung, Indonesia, (2001).
- [4] H. Ramza, A. Maddu, A. Syahriar, and H. Zain, "Underwater fiber optic sensor for detecting of acoustical wave disturbance by using single mode optical fiber," *Physics Journal of the Indonesian Physical Society* vol. A5.0204, pp. 1-6, (2002).
- [5] H. Suyanto, A. Dahlan, and H. Ramzah, "Pengaruh ukuran diameter gulungan dan jumlah lilitan fiber optic terhadap efisiensi daya keluaran sinar laser," *Jurnal Fisika, Himpunan Fisika Indonesia*, vol. A5. 0543, pp. 1-3, (2002).
- [6] D. Marcuse, "Curvature loss formula for optical fibers," *J. Opt. Soc. Am.*, vol. 66, pp. 216-220, (1976).
- [7] D. Marcuse, *Light transmission optics*: Van Nostrand Reinhold, (1982).
- [8] R. R. A. Syms and J. R. Cozens, *Optical Guided Waves and Devices*: McGraw-Hill, (1992).
- [9] I. Valiente and C. Vassallo, "New formalism for bending losses in coated single-mode optical fibres," *Electronics Letters*, vol. 25, pp. 1544-1545, (1989).
- [10] P. Wang, Q. Wang, G. Farrell, G. Rajan, T. Freir, and J. Cassidy, "Investigation of macrobending losses of standard single mode fiber with small bend radii," *Microwave and Optical Technology Letters*, vol. 49, pp. 2133-2138, (2007).
- [11] J. Hecht, *Understanding fiber optics*: Pearson/Prentice Hall, 2006.
- [12] D. R. Anderson, L. Johnson, and F. G. Bell, *Troubleshooting Optical-fiber Networks: Understanding and Using Your Optical Time-domain Reflectometer*: Elsevier Academic Press, (2004).