



© Copyright Kemala Publisher  
All rights reserved

Science, Engineering and Social Science Series  
ISSN/e-ISSN: 2541 – 0369/2613 – 988X  
Vol. 4, No. 2, 2020, Printed in the Indonesia

## Service Quality, Customer Satisfaction, Customer Trust, and Customer Loyalty in Service of Paediatric Polyclinic Over Private H Hospital of East Jakarta, Indonesia

Christian Elizar<sup>1</sup>, Ratna Indrawati<sup>1,\*</sup>, Tantri Yanuar Rahmat Syah<sup>1</sup>

<sup>1</sup>Department of Hospital Administration, Universitas Esa Unggul Jakarta, Indonesia

Customer loyalty is considered as an important key to the success and profit of a hospital, so that a decrease in the number of visits from old patients or subscribed patients in the paediatric polyclinic of Private H Hospital is a serious problem. The purpose of this research is to determine the effect of service quality on customer loyalty with customer satisfaction and trust as an intervening variable in the services of a paediatric polyclinic in Private H Hospital. In this study, we used SEM method on 190 respondents to obtain the result. Here, the test results show has met the criteria of Goodness of Fit in which the t-value of service quality to customer satisfaction is 14.71, service quality to customer trust is 16.10, service quality to customer loyalty is 2.16, customer satisfaction to customer loyalty is 0.83, and customer trust to customer loyalty is 3.13. Customer trust significantly mediates the effect of service quality on customer loyalty while customer satisfaction cannot serve as a mediator since about 70% of patients at the paediatric polyclinic of Private H Hospital are National Health Insurance (JKN) members. By maintaining customer trust through the provision of services based on hospital accreditation standards and continuous evaluation, customer loyalty will increase as marked by the re-visit of patients even though there are other paediatric polyclinics offering more, even customers will recommend the paediatric polyclinic of Private H Hospital to other people.

**Keywords:** customer loyalty, service quality, customer satisfaction, customer trust

### 1. INTRODUCTION

Hospitals were seen as a social endeavor in the past, and have now shifted to socioeconomic ventures. Intense competition in hospital business is requires the management of these services to create strategies to maintain and even increase profits. Here, a strong market orientation within a company will be able to provide stronger and better satisfaction to buyers so the obtained results will be even greater [1]. Market orientation is a business philosophy since market orientation is a pattern of trust that helps individuals to understand organizational functions based on certain norms [2]. Thus, a market orientation as an operational view to the marketing core i.e. a focus on consumers and coordinated marketing so that the best quality of service can be created and will lead to customer loyalty. Customer loyalty is considered as an important key to the success and profit of the organization. Customer loyalty can be obtained by a com-

pany if customer satisfaction and trust have been achieved. It can be realized if the company can provide a good quality service. Service quality is often considered as an investment for a company, in which the efforts to increase it result in an increase in customers, an increase in the level of purchases from existing customers, and an increase in corporate profits [3]. Customer satisfaction is also a very desirable target for business since satisfied customers tend to buy more, re-visit, and spread positive opinions by word of mouth to other customers [4]. Customer satisfaction leads to greater customer loyalty, reduces future transactional costs, positively impacts company revenue and minimizes customer defection upon non-optimal quality [5]. Not less important, customer trust is also a target that must be achieved in business. Trust involves a person's expectation that others will behave in certain ways [6]. Trust between two parties requires that, if one party is not as expected, the other party will experience more negative results than if the

\*Email Address: [ratna.indrawati@esa.unggul.ac.id](mailto:ratna.indrawati@esa.unggul.ac.id)

other behaves as expected [7]. Trust is considered an important element of customer perceptions about brands and companies [8]. Trust is beneficial for customers and companies. The benefit for customers is reduced risk perception to service providers. Meanwhile, companies benefit through increased sales, reduced costs, word of mouth and even employee retention [9, 10].

Private H Hospital (RSSH) is a type B private public hospital accredited by the KARS plenary in 2019. The hospital was inaugurated on 18 June 1984, and is located in East Jakarta, Indonesia. From the medical record unit at RSSH, data on the number of patient visits was obtained. The biggest decline in visits over the past 5 years occurred in the pediatric polyclinic. In 2014, there were 35,603 patient visits to RSSH's pediatric polyclinic, consisting of 3,405 new patients and 32,198 old patients. In 2015, it decreased to 31,446 visits consisting of 2,835 new patients and 28,611 old patients. In 2016, it dropped to 22,039 visits consisting of 1,878 new patients and 20,161 old patients. Then, it went down again in 2017 to 13,212 visits consisting of 1,063 new patients and 12,149 old patients. Even though the patient visit to the pediatric polyclinic at RSSH increased in 2018 compared to the previous year of 15,667 visits consisting of 1,503 new patients and 14,164 old patients, RSSH still must be vigilant and continue to evaluate to prevent further decrease in the number of customer visits to the pediatric polyclinic. From the above data, it can be seen that the largest number of visits comes from old patients or patients who have subscribed to the RSSH's pediatric polyclinic. The number of new-patient visits is only about 10% of the number of old-patient visits. The biggest decrease in the number of visits comes from old patients. The large decrease in the number of subscribed-patient visits indicates a problem in customer loyalty. According to the above explanation, the writer is interested in conducting research on the effect of service quality on customer loyalty with customer satisfaction and trust as an intervening variable in the service of the pediatric polyclinic at RSSH, East Jakarta.

In general, the purpose of this research is to determine the effect of service quality on customer loyalty with customer satisfaction and trust as an intervening variable in the service of the pediatric polyclinic at RSSH. Specifically, the purpose of this research is: to analyze the effect of service quality to customer satisfaction of the pediatric polyclinic at RSSH, to analyze the effect of service quality to customer trust of the pediatric polyclinic at RSSH, to analyze the effect of service quality to customer loyalty of the pediatric polyclinic at RSSH, to analyze the effect of customer satisfaction to customer loyalty of the pediatric polyclinic at RSSH, and to analyze the effect of customer trust to customer loyalty of the pediatric polyclinic at RSSH.

## 2. METHODOLOGY

The variables used in this research are:

1. Customer Loyalty, have a intensity of customers to make repeated purchases and use services in the same category without moving or switching to other service providers and provide recommendations either individually or collectively for a product or service aiming to provide personal information. Therefore, the dimensions it contains are subscription, displacement behavior, and word-of-mouth recommendation [11].
2. Service Quality, the reflection of evaluative customer perceptions of service received at a certain time. Therefore, the dimensions it contains are tangibility, reliability, assurance, and empathy [12].
3. Customer Satisfaction is the conformity of expectations with what is felt over the performance of a product that encourages customers to visit, repurchase, and recommend the product to friends or family. Therefore, the dimensions it contains are the suitability of expectation, the interest to re-visit, and the willingness to recommend [13, 14].
4. Customer Trust is a willingness of a person to be sensitive to the actions of others under the expectation that others will take certain actions to people who trust them, without depending on their abilities to supervise and control them. Therefore, the dimensions it contains are the ability, benevolence, and integrity (see Figure 1) [15].

### A. Research Constellation

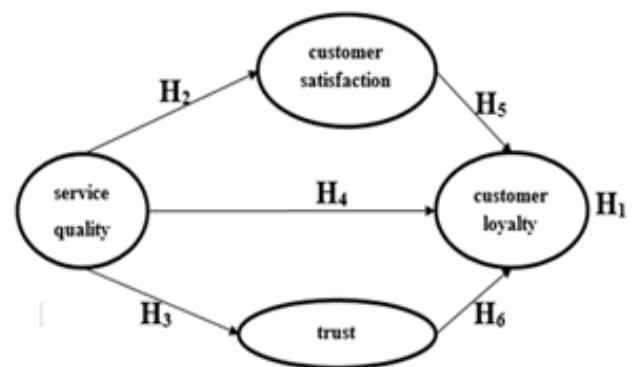

Figure 1. Research Constellation

### Hypothesis Development

1. **H<sub>1</sub>**: Service quality affects customer loyalty with customer satisfaction and trust as an intervening variable
2. **H<sub>2</sub>**: Service quality affects customer satisfaction
3. **H<sub>3</sub>**: Service quality affects customer trust
4. **H<sub>4</sub>**: Service quality affects customer loyalty
5. **H<sub>5</sub>**: Customer satisfaction affects customer loyalty
6. **H<sub>6</sub>**: Customer trust affects customer loyalty

B. Research Method

The conducted research is a descriptive research. It uses a survey i.e. cross-sectional survey. This research is an explanatory research aiming to explain the causal relationship (affect) and test the hypotheses. It aims to discover the effect of service quality (X), satisfaction (Z1), and trust (Z2) to customer loyalty (Y) in the services of the pediatric polyclinic at RSSH. Referring to its data collection method, this research is a survey research that takes samples to be examined and uses questionnaires as a tool to collect primary data. The data was obtained through questionnaires distributed to respondents and containing statements and answers of respondents in form of a Likert scale with 5 measurement scales. The index values of variables are interpreted with the Three Box Method criteria. In association with the method of analysis, this research is a quantitative research with SEM analysis technique using LISREL statistical software version 8.70. The population of this research is all old patients of the pediatric polyclinic at RSSH who visited in November 2019 with a total of 1,377. The sample of this research is the parents of patients who have been treated at least twice in 2019 at the pediatric polyclinic of RSSH who visited during the research. Samples were taken using Hair formula. In this research, the number of items is 38 questions used to measure 4 variables, thus the required minimum number of samples is  $38 \times 5 = 190$  respondents, plus 10% to anticipate dropout into 209. However, since some respondents incompletely answered the questionnaires, the questionnaires used in this research are 190. A pre-test was conducted to test validity using Kaiser Meyer Olkin (KMO) to discover whether there was a correlation among the variables. The acceptable KMO value is above 0.500. For validity, each research questionnaire was tested using Anti-Image Matrix. The expected MSA (Measure of Sampling Adequacy) value is a minimum of 0.500 [3]. Then, it continued to reliability test to discover the extent to which the gauges could be trusted, and to measure the extent of the consistency of measuring instruments for this research. The reliability test was performed using Alpha Cronbach's method. If the value is greater than 0.5, the research instrument is declared reliable.

3. RESULT AND DISCUSSION

Most respondents are female with the percentage of 65.26%. The majority are of 18-30 years old with the percentage of 66.32%. Meanwhile, regarding educational characteristics, the majority of respondents hold D1-S3 titles with the percentage of 71.05% (see Table I, Table II, and Figure 2).

Table I. Construction Validity Measurement Result

Dimensions	Variable	Loading Factor	T-Value	Result
L1	Loyalty (L)	0,95	0	Accepted
L2		0,92	25,13	Accepted
L3		0,92	25,03	Accepted
L4		0,91	24,85	Accepted
L5		0,91	24,46	Accepted
L6		0,88	18,43	Accepted
KPD1	Service Quality (KP)	0,92	16,58	Accepted
KPD2		0,92	16,54	Accepted
KPD3		0,90	15,93	Accepted
KPD4		0,88	15,44	Accepted
KPD5		0,91	16,33	Accepted
KD1	Customer Satisfaction (K)	0,94	0	Accepted
KD2		0,92	22,20	Accepted
KD3		0,95	20,63	Accepted
KCD1	Trust (KC)	0,93	0	Accepted
KCD2		0,95	26,61	Accepted
KCD3		0,90	22,11	Accepted

Source: own research

Table II. Goodness of Fit Index Analysis Result

Group	Indicator	Value	Result
1	Degree of Freedom	110	Good fit
	Chi Square	175,63	
	NCP	71,95	
	Confidence Interval	38,78 ; 113,02	
2	RMSEA	0,059	Good fit
	Confidence Interval	0,043 ; 0,074	
	P-value	0,17	
3	ECVI Model	1,42	Good fit
	ECVI Saturated	1,62	
	ECVI Independence	86,40	
	Confidence Interval	1,24 ; 1,64	
4	AIC Model	267,95	Good fit
	AIC Saturated	306,00	
	AIC Independence	16402,63	
	CAIC Model	450,57	
	CAIC Saturated	955,79	
5	CAIC Independence	16402,63	Good fit
	NFI	0,99	
	CFI	1,00	
	NNFI	0,99	
	IFI	1,00	
	RFI	0,99	
6	PNFI	0,80	Marginal fit
	Critical N (CN)	159,63	
7	Standardized RMR	0,018	Good fit
	GFI	0,90	
	AGFI	0,86	
	PGFI	0,65	

Source: own research

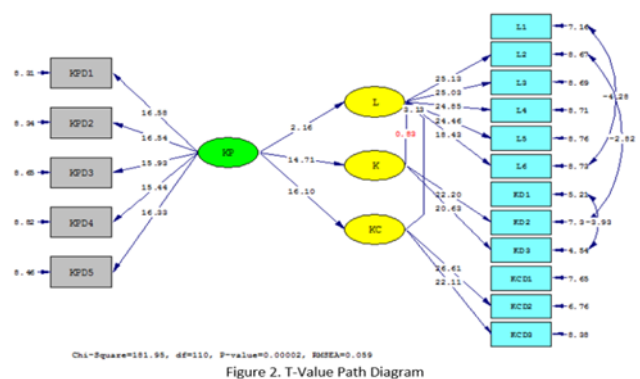

Figure 2. T-Value Path Diagram

*A. Hypothesis Test****Service Quality (X) Does Not Affect Customer Loyalty (Y) with Customer Satisfaction (Z1) and Trust (Z2) as Intervening Variables***

The requirement for mediation test is that variable X to variable Z is significant and variable Z to variable Y is significant. Meanwhile, referring to the above hypothesis test i.e. X (Service Quality) → Z1 (Satisfaction) and Z2 (Trust) → Y (Loyalty), one mediator (Z1) fails to mediate the effect of (X) to (Y). Therefore, it is concluded that service quality does not affect customer loyalty with customer satisfaction and trust as an intervening variable.

Customer loyalty is directly proportional to service quality and customer trust, but does not directly proportional to customer satisfaction at the pediatric polyclinic of RSSH. Satisfaction alone cannot always guarantee a person to continue to be a customer since there are still many other aspects also affecting one's desire to remain subscribed namely, in this research, the trust aspect. It indicates that, related to the customers of pediatric polyclinic of RSSH, it is not sufficient to only pay attention to their satisfaction. RSSH must further enhance its ability, benevolence, and integrity so customer trust gets higher and ultimately also increases customer loyalty. The results of this research are in line with 8% variant of loyalty can be explained by satisfaction variable, so customer satisfaction variable almost always does not affect customer loyalty.

Therefore, the result of this research is not improve quality has a strong positive impact on loyalty through customer satisfaction and customer trust, and loyalty is also positively affected by customer satisfaction and customer trust in e-banking. We found that a service quality factor has an indirect relationship with loyalty factor through satisfaction factor. Moreover, in this research a banking services also concludes that customer satisfaction entirely / partially mediates the relationship between service quality and customer loyalty.

***Service Quality Affects Customer Satisfaction***

The test result of second hypothesis (H2) shows that the result of analysis supports the H2 hypothesis i.e. good service quality will increase customer satisfaction. The result of this test indicates that service quality affects satisfaction. It can be seen that the service quality of the pediatric polyclinic at RSSH is able to provide satisfaction to its customers. Customer satisfaction is the result of an evaluation of a product or service whether the product and service have met the boundary between consumer needs and expectations. Good service can provide satisfaction. Customers expect that with the money they have spent to pay for each service product they get (health services, health support, and medicine), they expect and demand that health workers can provide the services they expect. If customers obtain the best quality of service, they will be satisfied, and, vice versa, if they obtain poor service quality, they will feel disappointed and will tell their disappointment to their friends or others. It is a big loss for

RSSH. The level of service quality will greatly determine the level of customer satisfaction to a service provided by a service provider, while the level of quality in service will greatly support the establishment of customer satisfaction to the service customers receive. The result of this research is in line with the dimensions of service quality, such as politeness, assurance, response, empathy, tangibility, and reliability have a significant positive affect on satisfaction. A service quality positively affects satisfaction. Here, a service quality has a strong positive impact to loyalty, along with customer satisfaction and customer trust. Thus, service quality factor has a direct relationship with satisfaction factor where service quality positively affects patient satisfaction. Even in the context of the banking industry, also concludes that overall service quality is the antecedent of customer satisfaction. A service quality has a positive impact to satisfaction with quality of internet banking services has a positive relationship with customer satisfaction.

***Service Quality affect Customer Trust***

The test result of third hypothesis (H3) shows that the result of analysis supports the H3 hypothesis i.e. appropriate service quality will increase customer trust. It indicates the quality of service at the pediatric polyclinic of RSSH is able to provide trust to customers. Customers are the primary focus in the business since, without customers, companies cannot generate income to run their businesses. Therefore, the main thing to do is to provide quality services so as to create trust to get customers who are loyal to the company. Customer trust will arise since there is a belief that the parties involved in the exchange will provide consistent, honest, and responsible quality. This belief will lead to good relations between parties involved in the exchange. According to the above analysis, it can be seen that the better the quality of services provided to customers, the higher the trust will increase. The result of this research is stating that service quality positively affects trust. A service quality is found to have a strong positive impact to loyalty, along with customer satisfaction and customer trust. Here, service quality has a positive impact to trust. Even in the field of internet banking while is a positive relationship between the quality of internet banking service and customer trust.

***Service Quality Affects Customer Loyalty***

The test result of fourth hypothesis (H4) shows that the result of the analysis supports H4 hypothesis i.e. high service quality will increase customer loyalty. The emergence of customer loyalty is highly dependent on consumer perceptions and expectations to the obtained services. Service quality which can exceed expectations may lead to loyalty from customers. Customer loyalty can be in form of repeated visits to the pediatric polyclinic of RSSH on an ongoing basis. This condition makes it uneasy for customers to switch to other competitors due to their trust and dependence to the service quality provided

by RSSH. The existence of a dependency bond of service quality at the pediatric polyclinic of RSSH to loyalty enables customers to share their good experiences after using the service at the pediatric polyclinic of RSSH to the people close to them. The result of this research is in line with the previous research is stating that response, reliability, and empathy have a positive affect to loyalty. The retail services, also have Physical aspect provides a positive affect to customer loyalty to the store, reliability provides a positive affect to customer loyalty to the store, problem solving provides a positive affect to customer loyalty to the store, personal interaction provides a positive affect to customer loyalty to staffs. Here, in concludes that service quality positively affects loyalty also find that the relationship between loyalty and five dimensions: physical environment, customer-friendly staff, communication, responsiveness, and customer satisfaction is statistically significant. A banking service, conclude that overall service quality is the antecedent of customer loyalty. It is also in accordance with what was found a positive relationship between internet banking service quality and e-customer loyalty.

#### ***Customer Satisfaction Has No affect to Customer Loyalty***

The test result of fifth hypothesis (H5) shows that the result of the analysis does not support H5 hypothesis. It indicates that customer satisfaction does not affect customer loyalty at the pediatric polyclinic of RSSH. Satisfaction alone cannot always guarantee that someone will continue to be a customer since there are many other aspects also affecting one's desire to remain subscribed. From the statement above, it can be concluded that customer does not pay much attention to the suitability of their expectations with the experienced reality. The result shows that only about 8% variant of loyalty can be explained by satisfaction variable, so customer satisfaction variable almost always does not affect customer loyalty. Therefore, the result of this research is not in line with the previous research that satisfaction positively affects loyalty and positively affected by customer satisfaction and customer trust to e-banking. The same result is concluded by satisfaction factor has a direct relationship with loyalty factor between loyalty and customer satisfaction is statistically significant with banking industry, customer satisfaction is the antecedent of customer loyalty. Thus, the satisfaction has a positive impact to loyalty, and also have a positive relationship between e-customer satisfaction and e-loyalty.

#### ***Customer Trust Affects Customer Loyalty***

The test result of sixth hypothesis (H6) shows that the result of analysis supports H6 hypothesis i.e. customer trust affects customer loyalty. In other words, customer trust is directly proportional to customer loyalty at the pediatric polyclinic of RSSH.

The trust referred to in this research is how to build confidence and long-term relationships with the customers of the pediatric polyclinic of RSSH since the higher the customer trust level to a product, the higher the loyalty to the product. It indicates that the customers of pediatric polyclinic of RSSH are loyal since they trust the ability, benevolence, and also integrity of pediatric doctors and nurses at the pediatric polyclinic of RSSH in particular. The result of this research is in line with the previous research which is positively affects loyalty. Here, loyalty is positively affected by customer satisfaction and customer trust to e-banking. Thus, patient trust positively affects patient loyalty with a positive impact to loyalty. It is also consistent with the research conducted by impact of customer trust is found to have a positive relationship with electronic customer loyalty.

#### ***B. Research Findings***

1. Loyalty, All of its indicators have high weights. It indicates that customers at the pediatric polyclinic of RSSH have a high intensity to conduct repeated visits even though there are other pediatric polyclinics offering more, even customers will recommend the pediatric polyclinic of H Hospital to others.
2. Service Quality, In a statement regarding service quality, the lowest weight lies in the statement that I trust the ability of the pediatric doctors of RSSH. It indicates that customer is not really sure that there is a guarantee for the improvement of the patient's condition after visiting the pediatric doctors of RSSH.
3. Satisfaction, In a statement regarding service quality, the lowest weight lies in the statement that I will suggest my relatives to bring their children if they are sick to the pediatric polyclinic of RSSH since RSSH has complete laboratory facilities and their qualities are guaranteed. It indicates that laboratory examination at RSSH still needs to be completed. It can be overcome by collaborating with third parties to fulfill the completeness of supporting service facilities through clear agreements and by prioritizing patient's safety and comfort, for example collaborative laboratory examinations with third parties for examinations unable to be carried out at RSSH, so patients will not take long time to wait for the results.
4. Trust, All of its indicators have high weights. It indicates that customers have high trust to the ability, benevolence, and integrity of pediatric doctors and nurses at the pediatric polyclinic of RSSH.
5. Customer satisfaction does not affect customer loyalty at the pediatric polyclinic of RSSH. It is natural since about 70% patients at the pediatric polyclinic of RSSH are patients participating in National Health Insurance (JKN). JKN participants are required to follow tiered referral rules, so, even if patients feel dissatisfied, the majority of them will visit the hospital again for medical check-up.



#### 4. CONCLUSION

Service quality has a direct affect to customer loyalty and service quality has an indirect affect to customer loyalty through customer trust mediation. However, service quality does not indirectly affect customer loyalty through customer satisfaction mediation. Service quality affects customer satisfaction. Service quality affects customer trust. Service quality affects customer loyalty. Customer satisfaction does not affect customer loyalty. Customer trust affects customer loyalty. The pediatric polyclinic of RSSH, almost every year for the last 5 years, experiences decrease in the number of patient visits, especially old patients or subscribed patients. Therefore, the factors establishing customer loyalty can serve as a basis for hospital management to determine marketing strategies which should be used. According to the results of this research, in fact, the overall variables of loyalty, service quality, customer satisfaction, and customer trust have been included in high category, which means they are very good in the eyes of customers. There are several managerial implications which can be implemented by RSSH in an effort to increase customer loyalty, including:

1. In service quality aspect, the dimension of "assurance" still needs to be improved to increase customer trust in the ability of pediatric doctors which can be conducted by sponsoring pediatric doctors to participate in training activities, workshops, and seminars. The pediatric doctors of RSSH also have to smile more since it will create friendly and polite impressions, so customers become comfortable. RSSH must also be responsive and friendly as well as provide the best solutions if there are customers of the pediatric polyclinic who deliver complaints, inputs, or suggestions, so they will assume RSSH has a high sense of responsibility. From the dimensions of "tangibility", the cleanliness of bathrooms at the pediatric polyclinic of RSSH has to be improved by placing a cleaning service in the bathroom area who is always ready to clean the bathrooms of the pediatric polyclinic at all times.
2. In satisfaction aspect, the dimensions of "conformity of expectations" still needs to be improved and the completeness of facilities is quite meaningful to meet the expectations of customers of the pediatric polyclinic of RSSH in particular. Almost all customers are looking for complete and fast services. Therefore, the management can collaborate with third parties to fulfill the completeness of supporting service facilities through clear agreements and by prioritizing patient's safety and comfort, for example collaborative laboratory examinations with third parties for examinations unable to be carried out at RSSH, so patients will not take long time to wait for the results. In the dimension of "willingness to recommend", RSSH must complete laboratory examinations and improve its quality of services and medicines. In line with the efforts to improve service and medicine

qualities, the hospital needs to provide services based on hospital accreditation standards (medicine quality is based on pharmaceutical service and medicine use (PKPO)), so the service and medicine qualities provided to customers is in line or even above the standard, leading to increasing customer satisfaction.

3. Customer trust at the pediatric polyclinic of RSSH which has been very good can be maintained and even improved by collecting information systematically, as well as conducting continuous evaluation and monitoring of customer responses to services they receive, especially in terms of ability, benevolence, and integrity of health workers and other RSSH employees.
4. Customer loyalty is the final result of service quality and customer trust. Therefore, by achieving good service quality and high customer trust, high customer loyalty is also created at the pediatric polyclinic of RSSH. Hence, RSSH must continue to evaluate the service quality provided to customers to maintain customer trust.
5. For RSSH : It is expected to keep maintaining customer trust through service provision based on hospital accreditation standards and continuous evaluation, then customer loyalty will increase as marked by the re-visit of patients even though there are other pediatric polyclinics offering more, even customers will recommend the pediatric polyclinic of H Hospital to other people.
6. For other researchers :The results of this research are also expected to be developed by subsequent researchers through the addition of at least one other variable allegedly also affecting customer loyalty, for example brand image and payment system. The writer also hopes that subsequent researchers can examine more deeply about the four variables in this research with different research subjects to compare their results. In addition, subsequent researchers are expected to make improvements to the questionnaires and to conduct appropriate timing in distributing the questionnaires. Further research can be carried out in several hospitals.

#### References

- [1] Aykaç, D.S.O., Aydın, S., Ateş, M., Cetin, A.T. (2009). Effects of Service Quality on Customer Satisfaction and Customer Loyalty: Marmara University Hospital. *SSRN Electronic Journal*.
- [2] Carrizo Moreira, A., Freitas, P. M., and Ferreira, V. M. (2017). The effects of brand experiences on quality, satisfaction and loyalty: an empirical study in the telecommunications multiple-play service market. *Revista Innovar Journal Revista de Ciencias Administrativas y Sociales*, 27(64), 23-36.
- [3] Chhabra, K. (2018). Does Service Quality Matters in the Context of Internet Banking: A Perceptual Analysis of India's Internet Banking Customers Perception Regarding Service Quality, Trust, Satisfaction and Loyalty. *Journal of Commerce and Accounting Research*, 7(3), 52-60.
- [4] Chotivanich, P. (2014). Service Quality, Satisfaction, and Customer Loyalty in a Full-Service Domestic Airline in Thailand. *International Journal of Arts & Sciences*, 07(03), 161-169.
- [5] Chu, P. Y., Lee, G. Y., and Chao, Y. (2012). Service quality, customer satisfaction, customer trust, and loyalty in an e-banking context. *Social Behavior and Personality*, 40(8), 1271-1284.

- [6]. Deshpande, Rohit, John U. Farley, & Frederick E. Webster, Jr. (1993). Corporate Culture, Customer Orientation, and Innovativeness in Japanese Firms: A Quadrant Analysis. *Journal of Marketing*, 57 (1), 23-37.
- [7]. Tjiptono, Fandy. (2014). Pemasaran Jasa (Prinsip, Penerapan, Penelitian). Yogyakarta. Andi.
- [8]. Jaworski, B.J. and Kohli, A.K. (1996). Market Orientation: Review, Refinement, and Roadmap. *Journal of Market-focused Management*, Vol. 1 No. 2, pp. 119-35.
- [9]. Kumar, V., Pozza, I. D., & Ganesh, J. (2013). Revisiting the satisfaction-loyalty relationship: Empirical generalizations and directions for future research. *Journal of Retailing*, 89(3), 246-262.
- [10]. Mayer, R.C., Davis, J.H., and Schoorman, F.D. (1995). An Integrative Model of Organizational Trust. *Academy of Management Review*, 20, pp. 709-734.
- [11]. Minh, Ngo Vu And Huu, Nguyen Huan (2016). The Relationship between Service Quality, Customer Satisfaction and Customer Loyalty: An Investigation in Vietnamese Retail Banking Sector. *Journal of Competitiveness*. Vol. 8, Issue 2, pp. 103-116.
- [12]. Moreira, A. C., and Silva, P. M. (2015). The trust-commitment challenge in service quality-loyalty relationships. *International Journal of Health Care Quality Assurance*, 28(3), 253-266.
- [13]. Parasuraman, Valarie A. Zeithaml, and Leonard L. Berry. (1988). SERVQUAL: A Multiple-Item Scale for Measuring Consumer Perceptions of Service Quality. *Journal of Retailing*. Vol 64 (1) pp 12-37.
- [14]. Shpëtim, Cerri (2012). Exploring the Relationships Among Service Quality, Satisfaction, Trust and Store Loyalty Among Retail Customers. *Journal of Competitiveness* 4 (4). p. 16-3
- [15]. Slater, Stanley F., dan John. C. Narver. (1995). Market Orientation and The Learning Organization. *Journal of Marketing*. Vol 59, hal 63-74.
- [16]. Syah, T.Y.R. (2014). *Fasilitas Partisipasi Provider Sebagai Pembentuk Loyalitas Pelanggan, dengan Mediasi Kualitas Relasional, dan Dimoderasi Implicit Self Theorist*. Disertasi pada Program Doktorat Universitas Indonesia. Depok.

Received: 2 February 2020, Accepted: 17 April 2020